



CLIENT: Acro Aluminum (2024) Ltd.
5430 275 Street
Langley, British Columbia
V4W 3X7
Canada

Test Report No: QA-6407-DW-A	Issue Date: April 28, 2026
-------------------------------------	-----------------------------------

SAMPLE ID: Acro Aluminum (2024) Ltd. 400T Series Out-Swing Side-Hinged Door.

SAMPLING DETAIL: Test sample information was submitted directly to QAI for evaluation.

DATE OF RECEIPT: Documentation was received February 18, 2026, from Acro Aluminum (2024) Ltd..

TESTING PERIOD: Evaluation was conducted April 28, 2026.

AUTHORIZATION: Proposal QAI-5516 signed by Foad Raad, signed on February 2, 2026.

TEST PROCEDURE: Thermal simulation evaluation was performed following the methods outlined in the following standard:

CSA A440.2-22 Fenestration Energy Performance.

TEST RESULTS: Based on evaluation conducted by QAI, energy performance values for Acro Aluminum (2024) Ltd. 400T Series Out-Swing Side-Hinged Door is as found in Test Results section of this report for glazing options evaluated.

Prepared By

Florenz Somigao
Project Specialist

Signed for and on behalf of QAI Laboratories, Ltd.

Reviewed By

Digitally signed
by Jose Sanchez
Date:
2026.05.13
14:56:35 -04'00'

Jose Sanchez
Fenestration Reviewer

Printed from an info@qai.org document

This report is the confidential property of the client addressed. The report may only be reproduced in full. Publication of extracts from this report is not permitted without written approval from QAI. Any liability attached thereto is limited to the fee charged for the individual project file referenced. The results of this report pertain only to the specific sample(s) evaluated. Unless specifically stated or identified otherwise, QAI has utilized a Simple Acceptance rule per ILAC-G8 Section 4.2.1 to make conformity decisions on testing results contained in this report, as applicable.

TEST METHODS:

CSA A440.2-22

QAI Laboratories Ltd. (QAI) has performed energy performance thermal modeling in accordance with CSA A440.2-22. This thermal modeling was performed using software THERM 7.8 and WINDOW 7.8, with inputs outlined below for the noted 400T Series Out-Swing Side-Hinged Door evaluated.

Table 1. Acro Aluminum (2024) Ltd. 400T Series Out-Swing Side-Hinged Door evaluated to CSA A440.2-22.

PRODUCT	WIDTH (mm)	HEIGHT (mm)
400T Series Out-Swing Side-Hinged Door	960	2090

Air Leakage values of Acro Aluminum (2024) Ltd. 400T Series Out-Swing Side-Hinged Door noted above are included in Table 2 as shown below.

Table 2. Acro Aluminum (2024) Ltd. 400T Series Out-Swing Side-Hinged Door was evaluated to AAMA/WDMA/CSA 101/I.S.2/A440-22 NAFS - North American Fenestration Standard / Specification for windows, doors and skylights.

PRODUCT	TEST REPORT	REPORT DATE	TESTED SIZE		INFILTRATION (L/s·m ²)	EXFILTRATION (L/s·m ²)
			WIDTH (mm)	HEIGHT (mm)		
400T Series Out-Swing Side-Hinged Door	A-5048-DW-A-Revision 1	April 28, 2026	1085	2222	0.4	0.9

For the above noted products, the U-value, Solar Heat Gain Coefficient (SHGC), Visual Transmittance (VT) and Energy Rating (ER) were determined for the glazing options outlined in the Test Results section below, in accordance with CSA A440.2-22 with the software noted.

All drawings used in the modeling of the above noted fenestration products can be found in Appendix A to this report.

The test report and data were reviewed by QAI, and the air leakage results were deemed to be equal to NAFS 2017 ratings as referenced by CSA A440.2-22.

This report is the confidential property of the client addressed. The report may only be reproduced in full. Publication of extracts from this report is not permitted without written approval from QAI. Any liability attached thereto is limited to the fee charged for the individual project file referenced. The results of this report pertain only to the specific sample(s) evaluated. Unless specifically stated or identified otherwise, QAI has utilized a Simple Acceptance rule per ILAC-G8 Section 4.2.1 to make conformity decisions on testing results contained in this report, as applicable.



TEST RESULTS SUMMARY:
400T Series Out-Swing Side-Hinged Door
Size: 960 mm x 2090 mm

Class / Grille Bar Option #	Model Code	Number of Layers	Exterior Layer (mm)	Middle Layer (mm)	Interior Layer (mm)	Emissivity Surface 1	Emissivity Surface 2	Emissivity Surface 3	Emissivity Surface 4	Emissivity Surface 5	Emissivity Surface 6	Cavity 1 and 2 (mm)	Spacer Bar Type	Grille Bar	Reinforcement or Foam Insulation	Visual Transmittance Total Product	Product U-Factor (W/m ² K)	Product SHGC
G01	AA-SSOSHD-6,180(2)-6,CL-15AR90EN-F1	2	6 Cardinal LoE 180	-	6 Clear	-	0.068	-	-	-	-	14.5 90% Argon	EN	-	F1	0.44	2.54	0.37
G02	AA-SSOSHD-6,270(2)-6,CL-15AR90EN-F1	2	6 Cardinal LoE 270	-	6 Clear	-	0.035	-	-	-	-	14.5 90% Argon	EN	-	F1	0.39	2.50	0.23
G03	AA-SSOSHD-6,366(2)-6,CL-15AR90EN-F1	2	6 Cardinal LoE 366	-	6 Clear	-	0.020	-	-	-	-	14.5 90% Argon	EN	-	F1	0.36	2.48	0.18
G04	AA-SSOSHD-6,180(2)-6,189(4)-15AR90EN-F1	2	6 Cardinal LoE 180	-	6 Cardinal LoE 189	-	0.035	-	0.149	-	-	14.5 90% Argon	EN	-	F1	0.44	2.28	0.36
G05	AA-SSOSHD-6,270(2)-6,189(4)-15AR90EN-F1	2	6 Cardinal LoE 270	-	6 Cardinal LoE 189	-	0.068	-	0.149	-	-	14.5 90% Argon	EN	-	F1	0.38	2.39	0.22
G06	AA-SSOSHD-6,366(2)-6,189(4)-15AR90EN-F1	2	6 Cardinal LoE 366	-	6 Cardinal LoE 189	-	0.020	-	0.149	-	-	14.5 90% Argon	EN	-	F1	0.36	2.30	0.17
G07	AA-SSOSHD-6,180(2)-6,CL-15AR90EN	2	6 Cardinal LoE 180	-	6 Clear	-	0.068	-	-	-	-	14.5 90% Argon	EN	-	-	0.44	2.85	0.37
G08	AA-SSOSHD-6,270(2)-6,CL-15AR90EN	2	6 Cardinal LoE 270	-	6 Clear	-	0.035	-	-	-	-	14.5 90% Argon	EN	-	-	0.39	2.82	0.23
G09	AA-SSOSHD-6,366(2)-6,CL-15AR90EN	2	6 Cardinal LoE 366	-	6 Clear	-	0.020	-	-	-	-	14.5 90% Argon	EN	-	-	0.36	2.80	0.18
G10	AA-SSOSHD-6,180(2)-6,189(4)-15AR90EN	2	6 Cardinal LoE 180	-	6 Cardinal LoE 189	-	0.035	-	0.149	-	-	14.5 90% Argon	EN	-	-	0.44	2.66	0.36

This report is the confidential property of the client addressed. The report may only be reproduced in full. Publication of extracts from this report is not permitted without written approval from QAI. Any liability attached thereto is limited to the fee charged for the individual project file referenced. The results of this report pertain only to the specific sample(s) evaluated. Unless specifically stated or identified otherwise, QAI has utilized a Simple Acceptance rule per IAC-G8 Section 4.2.1 to make conformity decisions on testing results contained in this report, as applicable.

Class / Grille Bar Option #	Model Code	Number of Layers	Exterior Layer (mm)	Middle Layer (mm)	Interior Layer (mm)	Emissivity Surface 1	Emissivity Surface 2	Emissivity Surface 3	Emissivity Surface 4	Emissivity Surface 5	Emissivity Surface 6	Cavity 1 and 2 (mm)	Spacer Bar Type	Grille Bar	Reinforcement or Foam Insulation	Visual Transmittance Total Product	Product U-Factor (W/m ² K)	Product SHGC
G11	AA-SSOSHD-6,270(2)-6,189(4)-15AR90EN	2	6 Cardinal LoE 270	-	6 Cardinal LoE 189	-	0.068	-	0.149	-	-	14.5 90% Argon	EN	-	-	0.38	2.63	0.22
G12	AA-SSOSHD-6,366(2)-6,189(4)-15AR90EN	2	6 Cardinal LoE 366	-	6 Cardinal LoE 189	-	0.020	-	0.149	-	-	14.5 90% Argon	EN	-	-	0.36	2.62	0.17
G13	AA-SSOSHD-6,270(2)-6,CL-6,180(6)-10AR90EN-F1	3	6 Cardinal LoE 270	6 Clear	6 Cardinal LoE 180	-	0.068	-	-	-	0.035	14.5 90% Argon	EN	-	F1	0.34	2.12	0.20
G14	AA-SSOSHD-6,366(2)-6,CL-6,180(6)-10AR90EN-F1	3	6 Cardinal LoE 366	6 Clear	6 Cardinal LoE 180	-	0.020	-	-	-	0.035	14.5 90% Argon	EN	-	F1	0.31	2.12	0.16
G15	AA-SSOSHD-6,270(2)-6,CL-6,189(6)-10AR90EN-F1	3	6 Cardinal LoE 270	6 Clear	6 Cardinal LoE 189	-	0.068	-	-	-	0.149	14.5 90% Argon	EN	-	F1	0.34	2.15	0.21
G16	AA-SSOSHD-6,366(2)-6,CL-6,189(6)-10AR90EN-F1	3	6 Cardinal LoE 366	6 Clear	6 Cardinal LoE 189	-	0.020	-	-	-	0.149	14.5 90% Argon	EN	-	F1	0.32	2.14	0.16
G17	AA-SSOSHD-6,270(2)-6,180(4)-6,189(6)-10AR90EN-F1	3	6 Cardinal LoE 270	6 Cardinal LoE 180	6 Cardinal LoE 189	-	0.068	-	0.020	-	0.149	14.5 90% Argon	EN	-	F1	0.33	2.03	0.20
G18	AA-SSOSHD-6,270(2)-6,CL-6,180(6)-10AR90EN	3	6 Cardinal LoE 270	6 Clear	6 Cardinal LoE 180	-	0.068	-	-	-	0.035	14.5 90% Argon	EN	-	-	0.34	2.43	0.20
G19	AA-SSOSHD-6,366(2)-6,CL-6,180(6)-10AR90EN	3	6 Cardinal LoE 366	6 Clear	6 Cardinal LoE 180	-	0.020	-	-	-	0.035	14.5 90% Argon	EN	-	-	0.31	2.43	0.16
G20	AA-SSOSHD-6,270(2)-6,CL-6,189(6)-10AR90EN	3	6 Cardinal LoE 270	6 Clear	6 Cardinal LoE 189	-	0.068	-	-	-	0.149	14.5 90% Argon	EN	-	-	0.34	2.45	0.21
G21	AA-SSOSHD-6,366(2)-6,CL-6,189(6)-10AR90EN	3	6 Cardinal LoE 366	6 Clear	6 Cardinal LoE 189	-	0.020	-	-	-	0.149	14.5 90% Argon	EN	-	-	0.32	2.45	0.16
G22	AA-SSOSHD-6,270(2)-6,180(4)-6,189(6)-10AR90EN	3	6 Cardinal LoE 270	6 Cardinal LoE 180	6 Cardinal LoE 189	-	0.068	-	0.020	-	0.149	14.5 90% Argon	EN	-	-	0.33	2.34	0.20

This report is the confidential property of the client addressed. The report may only be reproduced in full. Publication of extracts from this report is not permitted without written approval from QAI. Any liability attached thereto is limited to the fee charged for the individual project file referenced. The results of this report pertain only to the specific sample(s) evaluated. Unless specifically stated or identified otherwise, QAI has utilized a Simple Acceptance rule per ILAC-G8 Section 4.2.1 to make conformly decisions on testing results contained in this report, as applicable.

400T Series Out-Swing Side-Hinged Door – Frame Representative Values (used for SHGC and VT calculations)							
Glass Layers	Model Code:	U-Factor Center-of-glass (1000 mm x 1000 mm IGU)	U-Factor Total Product	Dividers			
				NONE	<1"	≥1"	
3	AA-SSOSHD-6,270(2)-6,180(4)-6,189(6)-10AR90EN-LF1	0.703138	2.026016	SHGC ₀	0.021116	0.023900	0.026471
				SHGC ₁	0.603576	0.521464	0.445649
				VT ₀	0.000000	0.000000	0.000000
				VT ₁	0.582460	0.497564	0.419178

Notes:

- Surfaces are numbered from Exterior (1) to Interior.
- ER = 57.76(SHGC_w) – 21.90(U_w) – 1.97(L75) + 40
- All glazing surface emissivities are assumed to be 0.840 unless otherwise stated.
- The gas fill method is Single probe, gas type and concentration are noted for each glass option in the data table.
- All non-continuous hardware or components that do not create a thermal bridge were not modeled.
- Clear glass panes are permitted to be substituted with obscure glass as per CSA A440.2-22, Clause 4.2.5: “*Fenestration systems containing a decorative glazing life and in which the view through the glazing system is distorted (e.g., sandblasted glass, frosted glass, stained glass, or patterned glass) shall be treated as clear glass.*”
- Spacer Type:
 - o EN = Cardinal Endur™ IG Spacer Bar.
- Foam Type:
 - o F1 = (XPS) Foam Insulation inside the Frame Profile, see the assembly drawings for details.
- See the following page for the Model Code outline.

This report is the confidential property of the client addressed. The report may only be reproduced in full. Publication of extracts from this report is not permitted without written approval from QAI. Any liability attached thereto is limited to the fee charged for the individual project file referenced. The results of this report pertain only to the specific sample(s) evaluated. Unless specifically stated or identified otherwise, QAI has utilized a Simple Acceptance rule per ILAC-G8 Section 4.2.1 to make conformity decisions on testing results contained in this report, as applicable.

Thermal Simulation Model Codes for Doors

Model codes submitted to NRCAN for Energy Star must be no more than 60 characters with no spaces and no model code can be the same as another in their database.

Company ¹	Product Series and Type ²	Glass thickness, coating type and surface applied ³	Glass thickness, coating type and surface applied ⁴	Glass thickness, coating type and surface applied ⁵	Cavity width, gas and % fill, spacer bar type ⁶	Reinforcement or Foam Insulation ⁷	Dividers ⁸
XXXX	XXXXX	X,XXX(X)	X,XXX(X)	X,XXX(X)	XXXXXX	X	X

All Sections are separated by dashes, however if a code is over 60 characters remove the two dashes between the glazing layers and cavities. If a section is not needed such as the third glazing layer or the second cavity, that section will be deleted.

¹ Company code must be unique for each of our clients.

² Company's product series and type separated by dash. Exclude series if there is no product series or family.

Product Type:

- OSHD – Out-Swing Side-Hinged Door
- ISHD – In-Swing Side-Hinged Door
- FD – Folding Door
- GD – Garage Door
- TTD – Tilt & Turn Door
- SL – Sidelite
- FSL – Flush Glazed Sidelite
- TR – Transom
- OSDD – Out-Swing Double Door
- SD – Sliding Door
- LSD – Lift & Slide Door
- TSD – Tilt & Slide Door
- ISDD – In-Swing Double Door

^{3,4,5} Glass thickness (mm), Low-E coating type, surface applied to (in brackets).

- if the glass is clear indicate the size followed by CL: 3,CL

- if the glass has a Low-E coating, indicate the size followed by coating type and surface applied to in brackets: 3,8070(2)

⁶ Cavity is represented by size (mm rounded to whole number), then Gas Type, % fill, and spacer bar type: 8AR90TG or 13AR95SS.

Note: If the two cavity sizes, Gas Types, % fill, and spacer bar types are different, include both cavities, following the same order as glass (from exterior to interior). If the number of characters is outside the 60-character limit, this portion of the code should be truncated, as appropriate, to fit within the 60-character limit.

- Argon = AR
- Air = AIR
- Krypton = KR
- Xenon = XE

Spacer bar is represented by two letters for the name of the spacer, as indicated in the notes section of the results table.

⁷ Reinforcement or foam insulation in the sash or frame is indicated by 'R' or 'F', respectively. Exclude this section if there is no reinforcement or foam. If more than one reinforcement / foam configuration exists, use R1, R2 (F1, F2) and so on.

⁸ Dividers are represented with either 'G' for Simulated Divider and 'T' for True Divider, followed by <1 or >1, as applicable. Exclude this section if there is no divider. If more than one of the same type, use G1/T1 and G2/T2, followed by <1 or >1, as applicable.

Examples:

ABC Company Ltd., 4000XL Series Casement Window, with 3mm Cardinal 366 on surface 2, 12.7mm 90% Argon cavity with a TGI Spacer Bar, 3mm Clear glass = [ABC-4XLCA-3,366(2)-3,CL-13AR90TG]

Build Your Own Window Ltd., DIY 500 Series Single (Horizontal) Sliding Window with 3mm Cardinal 366 on surface 2, 4mm Cardinal 270 on surface 3 and 3mm Cardinal i89 on surface 6 with 9.5mm cavities 95% Argon (cavity 1) and Air (cavity 2) with Superspacer Standard and 35 mm wide True Divided Lites = [BYOW-DIY5SS-3,366(2)-4,270(3)-3,i89(6)-10AR95SS-10AIRSS-T>1]

APPENDIX A

Page	Title
8	Material List
9 - 14	Assembly Drawings
15 - 19	Die Drawings
20	Spacer Bar Details

MATERIAL LIST

Part	Material	Conductivity (W/m*K)
Frame / Sash / Aluminum Threshold / Glazing Stop	Aluminum alloys (Anodized)	160.0000
Thermal Breaks	Polyamide (PA 66/Nylon – 25% Glass Fill)	0.3000
Compression Glazing Gaskets	Ethylene Propylene Diene Monomer	0.2500
Bulb Seal Gaskets	Silicone	0.3500
Foam	Extruded Polystyrene (XPS)	0.0340
Mohair Pile Seal	Mohair (polyester) sweep	0.1400
Thermal Break Strip	Polyurethane	0.2500
Cardinal Endur™ IG Spacer Bar		
Primary Sealant	Silicone	0.3500
Secondary Sealant	Polyisobutylene (PIB)	0.2000
Desiccant	Desiccant–molecular sieve	0.1000
Steel Wire	Cardinal Stainless Steel	14.1870

ASSEMBLY DRAWINGS

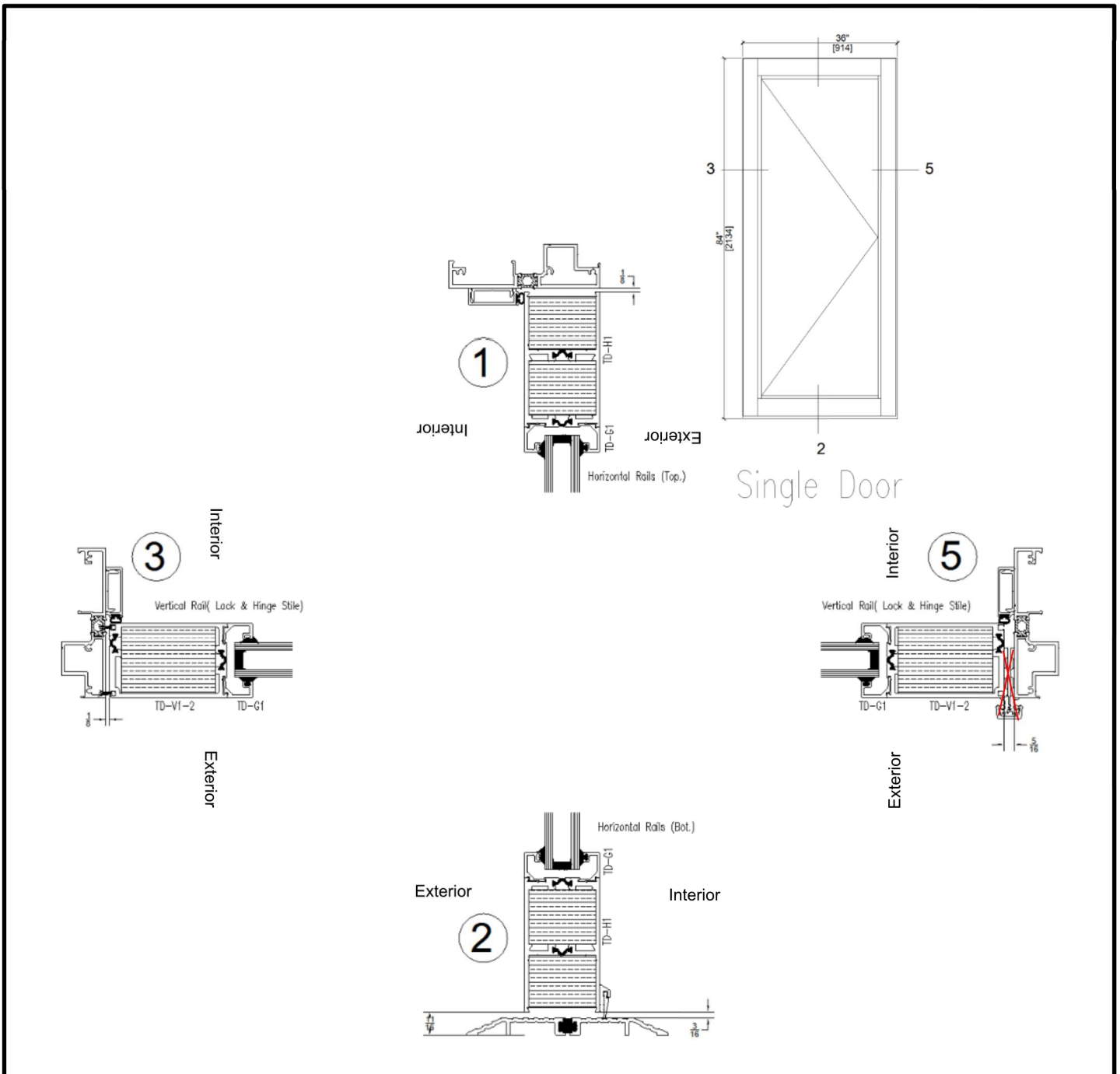

400T Series Out-Swing Side-Hinged Door – Assembly Drawings with Foam.

This report is the confidential property of the client addressed. The report may only be reproduced in full. Publication of extracts from this report is not permitted without written approval from QAI. Any liability attached thereto is limited to the fee charged for the individual project file referenced. The results of this report pertain only to the specific sample(s) evaluated. Unless specifically stated or identified otherwise, QAI has utilized a Simple Acceptance rule per ILAC-G8 Section 4.2.1 to make conformity decisions on testing results contained in this report, as applicable.

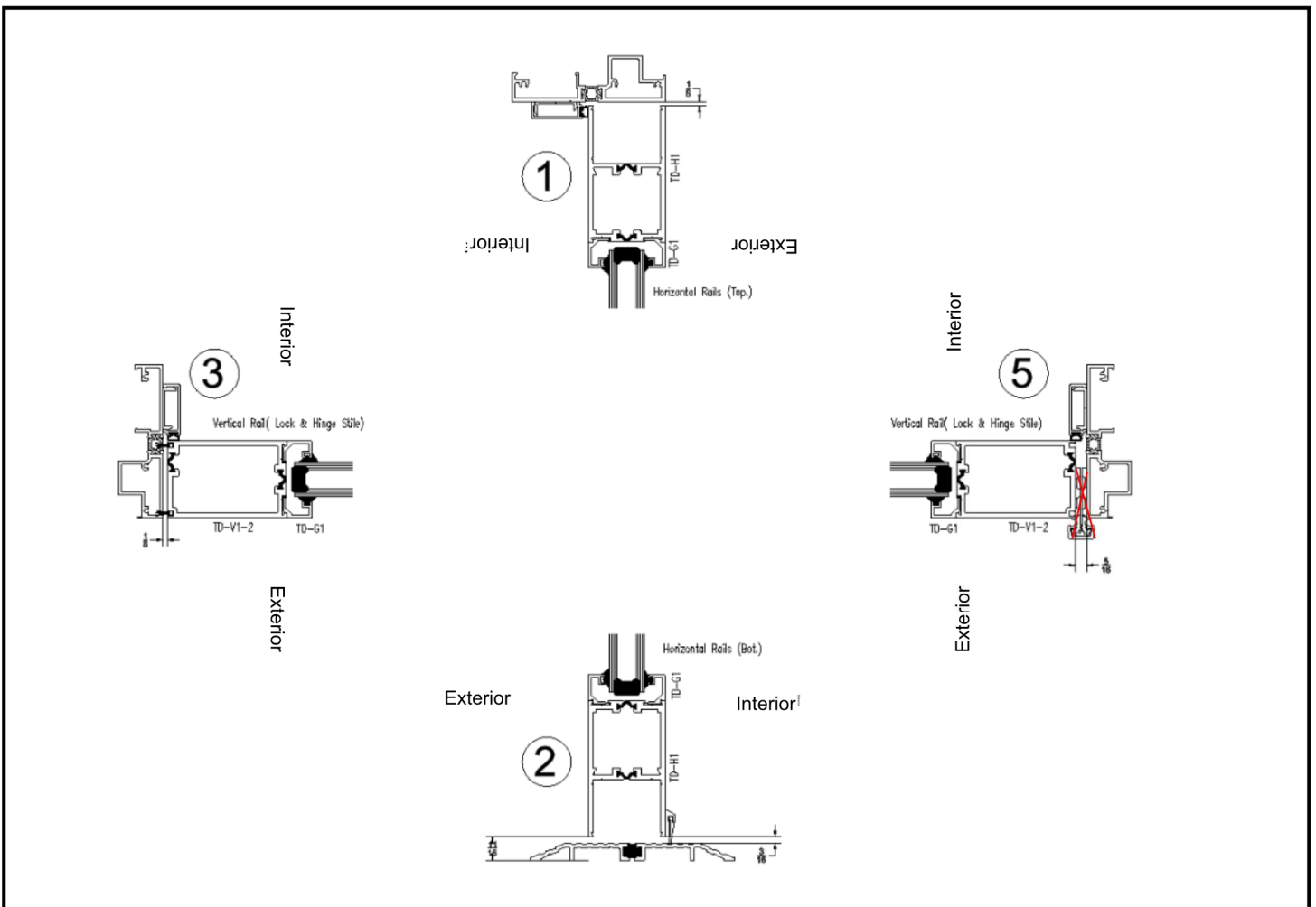

400T Series Out-Swing Side-Hinged Door – Assembly Drawings without Foam.

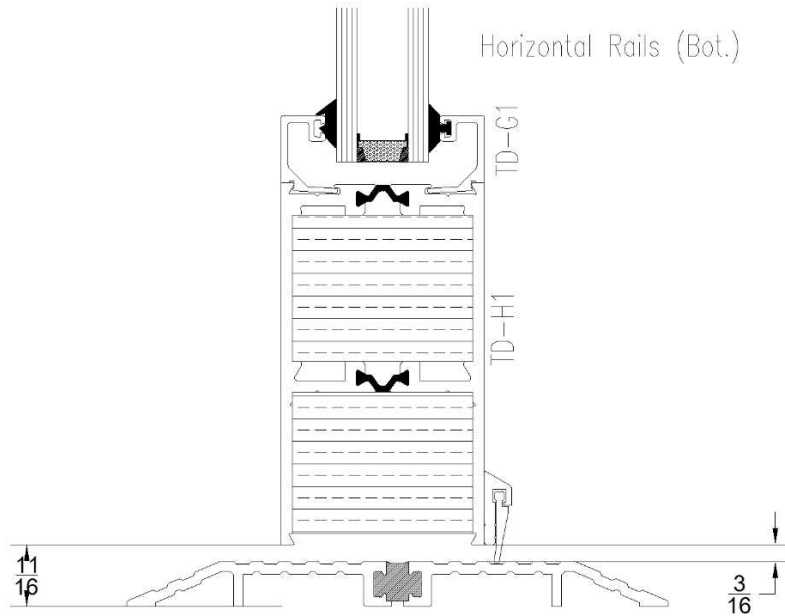

400T Series Out-Swing Side-Hinged Door – Sill Profile.

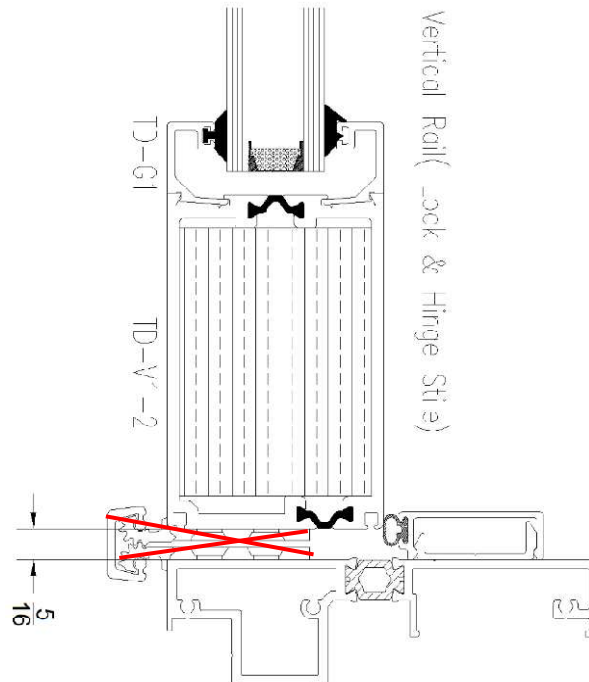

400T Series Out-Swing Side-Hinged Door – Right Jamb Profile.

This report is the confidential property of the client addressed. The report may only be reproduced in full. Publication of extracts from this report is not permitted without written approval from QAI. Any liability attached thereto is limited to the fee charged for the individual project file referenced. The results of this report pertain only to the specific sample(s) evaluated. Unless specifically stated or identified otherwise, QAI has utilized a Simple Acceptance rule per ILAC-G8 Section 4.2.1 to make conformity decisions on testing results contained in this report, as applicable.

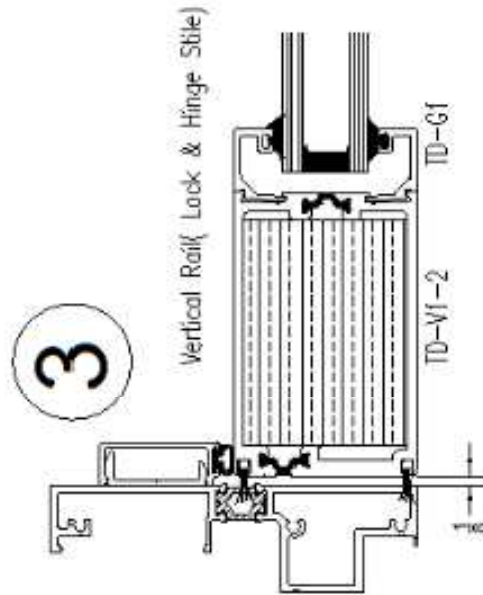

400T Series Out-Swing Side-Hinged Door – Left Jamb Profile (with Foam).

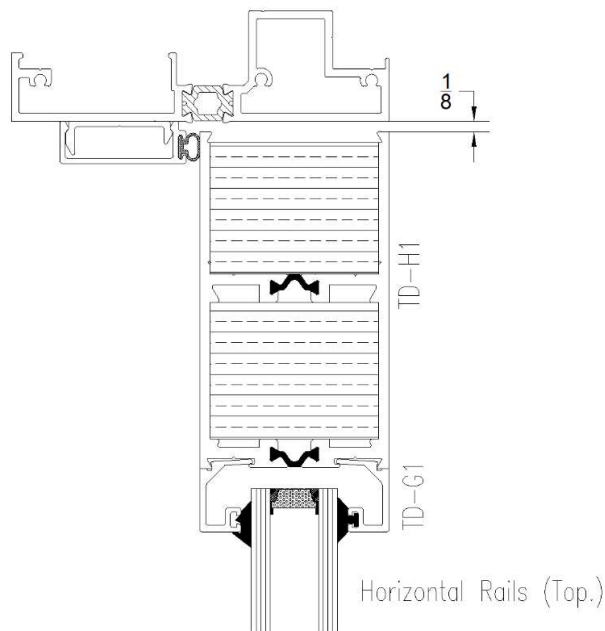

400T Series Out-Swing Side-Hinged Door – Head Profile (with Foam).

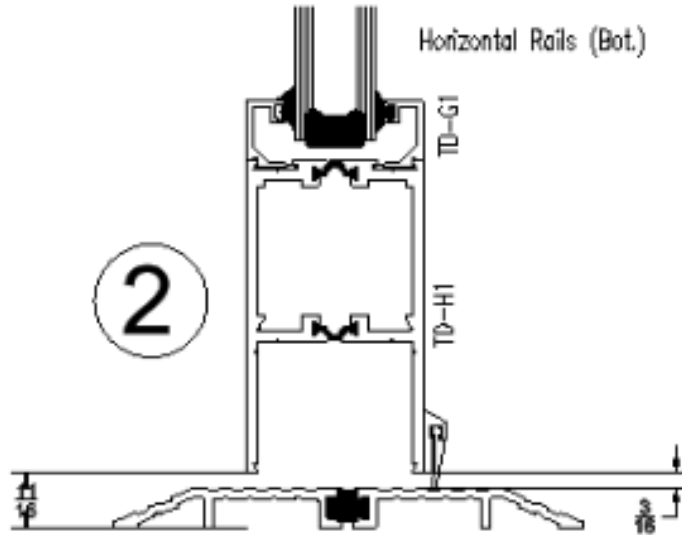

400T Series Out-Swing Side-Hinged Door – Sill Profile.

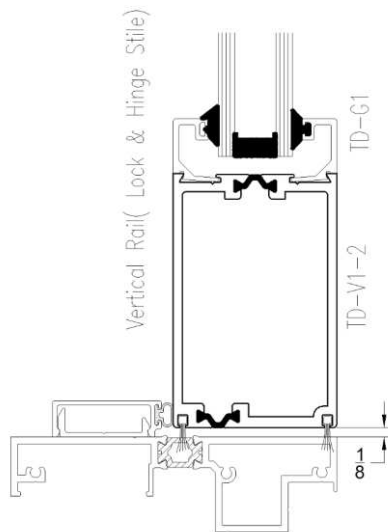

400T Series Out-Swing Side-Hinged Door – Left Jamb Profile

This report is the confidential property of the client addressed. The report may only be reproduced in full. Publication of extracts from this report is not permitted without written approval from QAI. Any liability attached thereto is limited to the fee charged for the individual project file referenced. The results of this report pertain only to the specific sample(s) evaluated. Unless specifically stated or identified otherwise, QAI has utilized a Simple Acceptance rule per ILAC-G8 Section 4.2.1 to make conformity decisions on testing results contained in this report, as applicable.

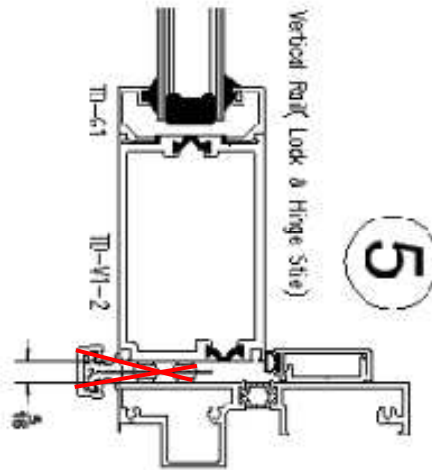

400T Series Out-Swing Side-Hinged Door – Right Jamb Profile

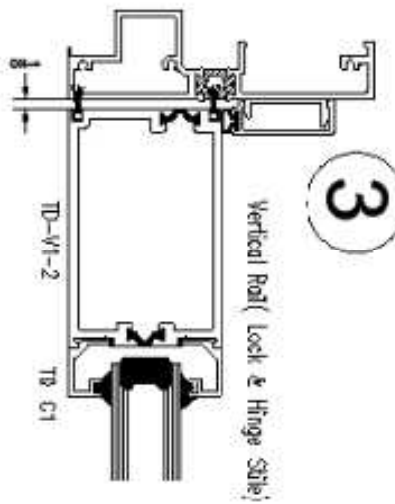

400T Series Out-Swing Side-Hinged Door – Head Profile.

PARTS DRAWINGS

All dimensions are in inches.

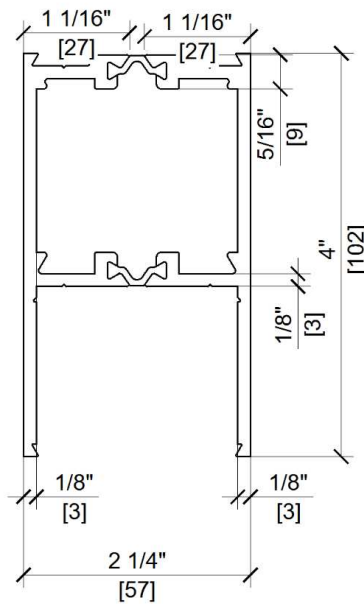

400T Series Out-Swing Side-Hinged Door - Sill Main Frame Profile

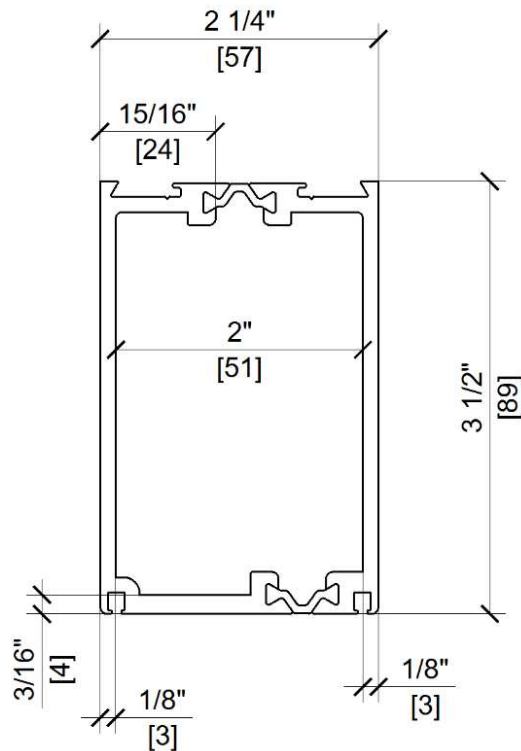

400T Series Out-Swing Side-Hinged Door - Jamb Main Frame Profile.

This report is the confidential property of the client addressed. The report may only be reproduced in full. Publication of extracts from this report is not permitted without written approval from QAI. Any liability attached thereto is limited to the fee charged for the individual project file referenced. The results of this report pertain only to the specific sample(s) evaluated. Unless specifically stated or identified otherwise, QAI has utilized a Simple Acceptance rule per ILAC-G8 Section 4.2.1 to make conformity decisions on testing results contained in this report, as applicable.

All dimensions are in inches.

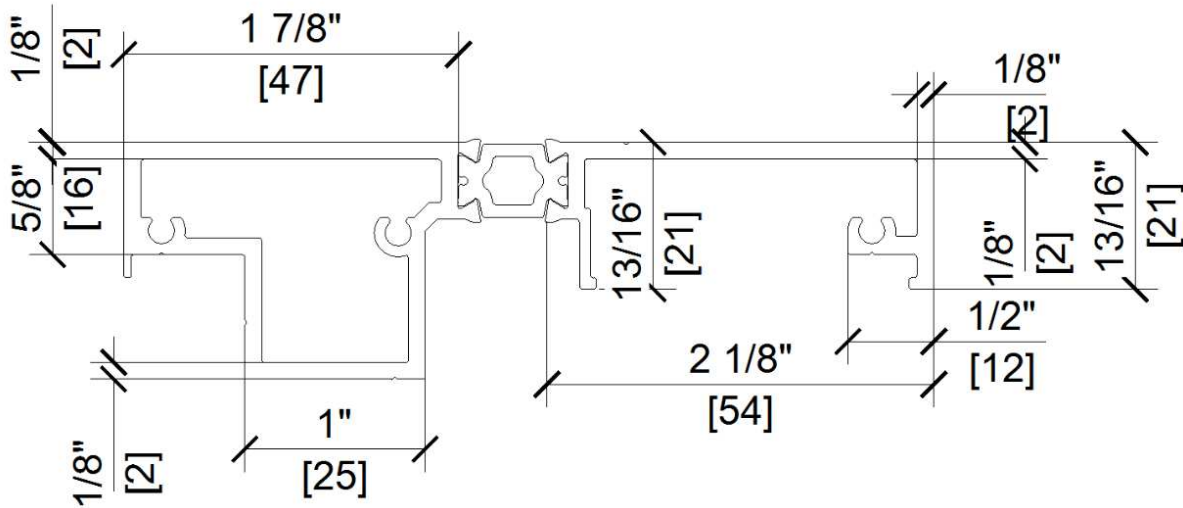

400T Series Out-Swing Side-Hinged Door - Door Adaptor

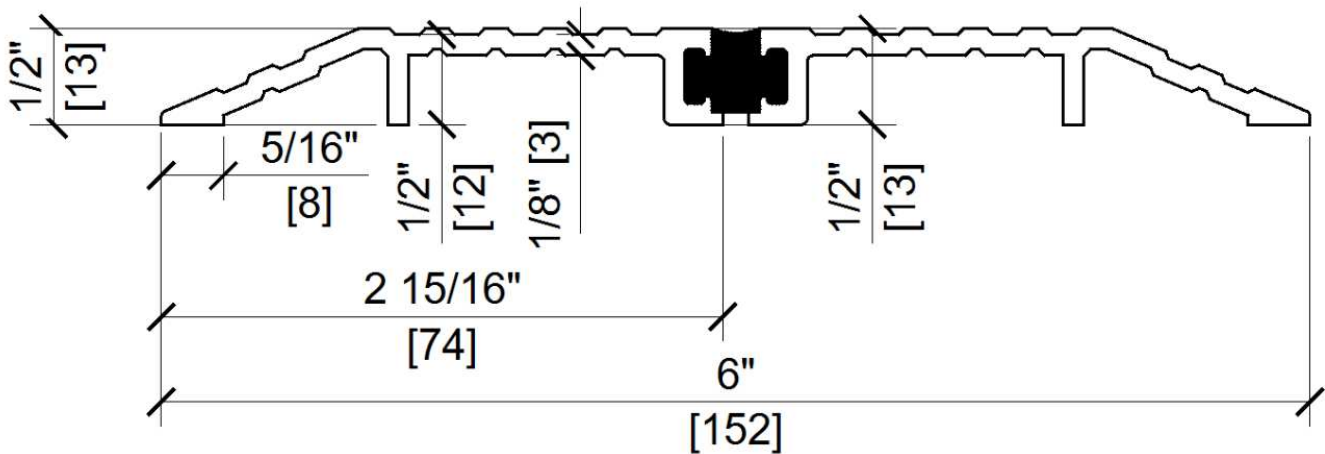

400T Series Out-Swing Side-Hinged Door - Aluminum Threshold

This report is the confidential property of the client addressed. The report may only be reproduced in full. Publication of extracts from this report is not permitted without written approval from QAI. Any liability attached thereto is limited to the fee charged for the individual project file referenced. The results of this report pertain only to the specific sample(s) evaluated. Unless specifically stated or identified otherwise, QAI has utilized a Simple Acceptance rule per ILAC-G8 Section 4.2.1 to make conformity decisions on testing results contained in this report, as applicable.

All dimensions are in inches.

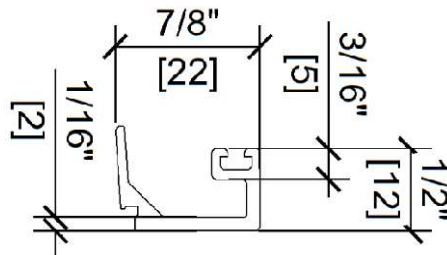

400T Series Out-Swing Side-Hinged Door - Dual Glazing Stop

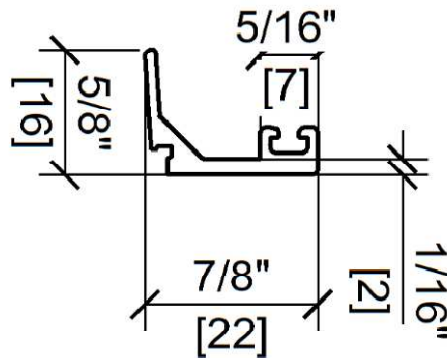

400T Series Out-Swing Side-Hinged Door - Triple Glazing Stop.

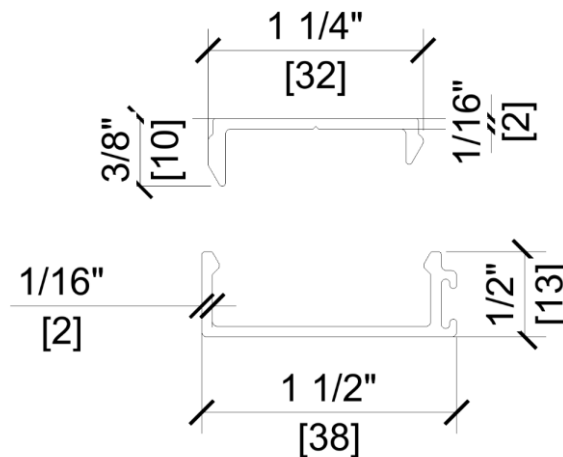

400T Series Out-Swing Side-Hinged Door – Aluminum Cover profile.

This report is the confidential property of the client addressed. The report may only be reproduced in full. Publication of extracts from this report is not permitted without written approval from QAI. Any liability attached thereto is limited to the fee charged for the individual project file referenced. The results of this report pertain only to the specific sample(s) evaluated. Unless specifically stated or identified otherwise, QAI has utilized a Simple Acceptance rule per ILAC-G8 Section 4.2.1 to make conformity decisions on testing results contained in this report, as applicable.

All dimensions are in inches.

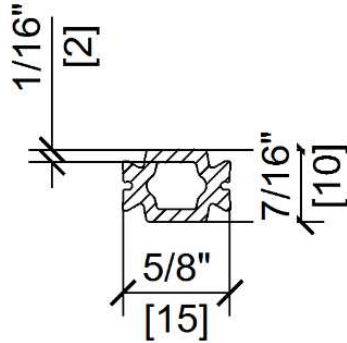

400T Series Out-Swing Side-Hinged Door - Thermal Break 1

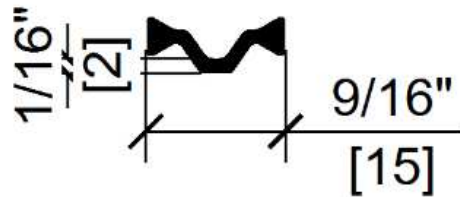

400T Series Out-Swing Side-Hinged Door - Thermal Break 2

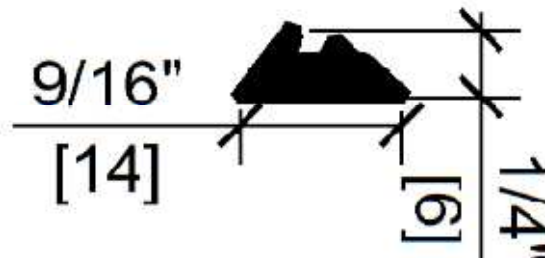

400T Series Out-Swing Side-Hinged Door - Interior Glazing Gasket.

All dimensions are in inches.

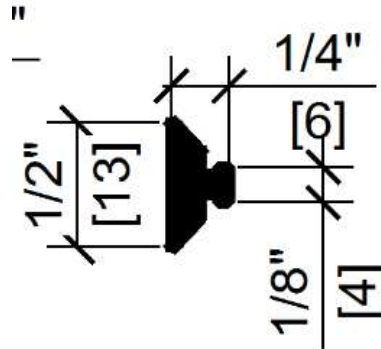

400T Series Out-Swing Side-Hinged Door - Exterior Glazing Gasket.

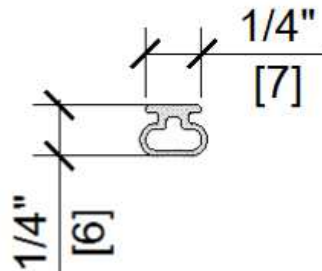

400T Series Out-Swing Side-Hinged Door - Compression Gasket.

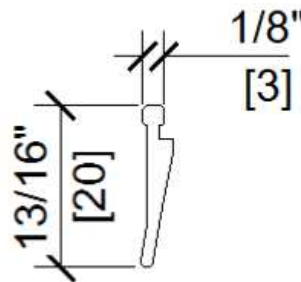

400T Series Out-Swing Side-Hinged Door - Mohair (polyester) sweep.

SPACER BAR DETAILS

CARDINAL IG

Endur IG™ Simulation Model

The purpose of this guide is to help properly model the Endur IG™ seal system when performing Therm window simulations.

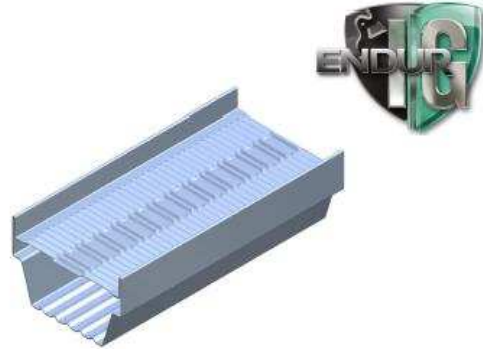

Endur IG™ Edge geometry

Shown here is the simplified Endur IG™ geometry that should be used for thermal models. This geometry is also included within the attached Endur IG Therm.thm therm file.

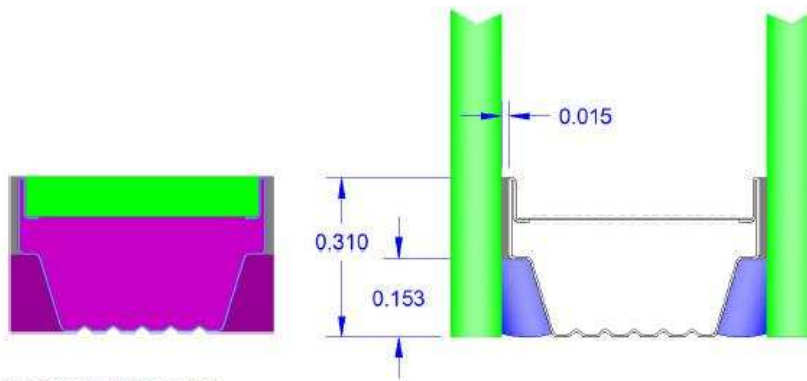

Some important items are:

- PIB thickness is 0.015".
- Spacer back even with glass edge.
- Stainless steel thickness is 0.0045" along the sides and back of the spacer and 0.002" across the middle of the spacer for most airspaces.

Thermal conductivity

The following thermal conductivity values should be used when modeling Endur IG™.

- Silicone: 0.202 BTU/hr-ft-F (0.350 W/m-K)
- PIB [ADCO PIB-8 HSNB Gray]: 0.089 BTU/hr-ft-F (0.155 W/m-K)
- Desiccant [desiccant-loose fill]: 0.017 BTU/hr-ft-F (0.030 W/m-K)
- Spacer [Cardinal Stainless Steel]: 8.197 BTU/hr-ft-F (14.187 W/m-K)

Endur IG Simulation Model 2012-12-14

Cardinal Endur™ IG Spacer Bar

Report Revision History

Date	Revision	Change Description	Initials
April 28, 2026	0	Original Test Report. <ul style="list-style-type: none">• 400T Series Out-Swing Side-Hinged Door:<ul style="list-style-type: none">○ 22 Glass Options.	FAS

*****<END OF REPORT>*****